

Customer.: M/s. \_\_\_\_\_  
 PROJECT.: M/s. \_\_\_\_\_  
 P.O.No.: \_\_\_\_\_ Date.: \_\_\_\_\_  
 W.O.No.: \_\_\_\_\_ Date.: \_\_\_\_\_

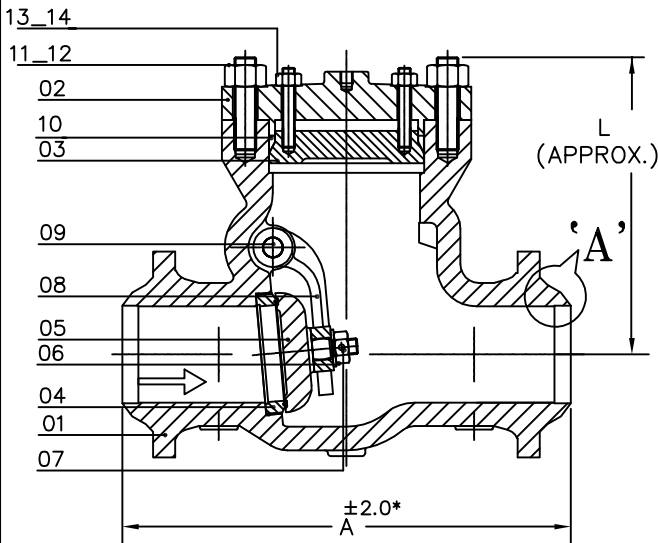

**CAST STEEL  
 PRESSURE SEAL CHECK VALVE**

DWG.NO.: - SDSCV1500\_50-400      REV : 0



PART NO.	PART NAME	MATERIAL		QTY
01	BODY	ASTM A216 Gr. WCB	ASTM A217 Gr.WC6/WC9/C5/C12	1
02	BONNET	ASTM A216 Gr. WCB	ASTM A217 Gr.WC6/WC9/C5/C12	1
03	BOTTOM COVER	ASTM A216 Gr. WCB	ASTM A217 Gr.WC6/WC9/C5/C12	1
04	BODY SEAT	#	#	2
05	DISC SEAT	#	#	1
06	DISC NUT	SS304	SS304	1
07	SPLIT PIN	SS304	SS304	1
08	HINGE	ASTM A216 Gr. WCB	ASTM A217 Gr.WC6/WC9/C5/C12	1
09	HINGE PIN	ASTM A276 TP SS410	ASTM A276 TP SS410	1
10	GASKET	SOFTIRON	SS 304	1
11	BODY STUD	ASTM A 193 Gr. B7	ASTM A 193 Gr. B16	AS REQ.
12	BODY STUD NUT	ASTM A 194 Gr. 2H	ASTM A 194 Gr. 7	AS REQ.
13	BOTTOM COVER STUD	ASTM A 193 Gr. B7	ASTM A 193 Gr. B16	AS REQ.
14	BOTTOM COVER STUD NUT	ASTM A 194 Gr. 2H	ASTM A 194 Gr. 7	AS REQ.

NOTE.: Face to face as per ASME B 16.10.(2009)  
 Butt weld end as per ASME B 16.25.(2009)  
 DRAIN PLUG WILL BE PROVIDED ON REQUEST.  
 \* FOR SIZE 12" & ABOVE , ±3.0

Nos. 00

Date. 01/07/2011

REV.

**DESIGN STD.: API 600/ASME B 16.34**

CLASS	1500								
SIZE / NB	2"/50	3"/80	4"/100	6"/150	8"/200	10"/250	12"/300	14"/350	16"/400
A	216	305	406	559	711	864	991	1067	1194
øB(MIN)	47.5	69.9	91.9	136.4	177.8	222.3	263.4	288.8	330.2
L	150	200	250	375	450	500	600	600	725
WT IN KG.(APPROX)	40	50	70	280.	370	600	1350	1350	1800
QTY Nos.									

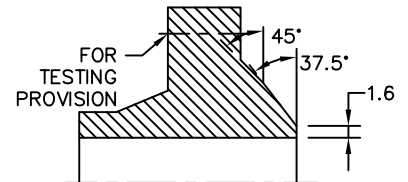

**DETAIL 'A'**

SPECIAL TRIM REQUIREMENTS		YES	NO
04	BODY SEAT	STELLITED	
04&05	BODY SEAT & DISC SEAT	STELLITED	

TEST STD.: API598/BSEN 12266 P-I

TEST PRESSURE		PSIG	Kg/cm <sup>2</sup>
HYDROSTATIC	SHELL	5575	392
	SEAT	4080	287

**STEEL STRONG** - APPROVED BY , ISO 9001-2008, (C) & (S) MARKING

API 6D-0315

ALL DIMENSIONS ARE IN MM UNLESS SPECIFIED

APPROVED BY C. S. Das

CHECKED BY Pankaj

PREPARED BY Pankaj

FOR APPROVAL

FOR REFERENCE